



6455 S. Dean Martin Drive, Suite C.  
 Las Vegas, Nevada 89118  
 Phone: (702) 309-8326 \* Fax: (702) 309-8328  
 Email: [orders@exposervicesdesk.com](mailto:orders@exposervicesdesk.com)  
 Order Online: [www.exposervicesdesk.com](http://www.exposervicesdesk.com)

|                                                 |  |                                          |                          |
|-------------------------------------------------|--|------------------------------------------|--------------------------|
| EVENT NAME: Vet Together & Smile Together 2026  |  | EVENT DATES: OCT 1-3, 2026               | LOCATION: LVCC - W1 & W2 |
| EXHIBITING COMPANY NAME:                        |  |                                          | BOOTH NUMBER:            |
| BILLING NAME (if different from above):         |  | Deadline for Advance Rate: SEPT 17, 2026 |                          |
| BILLING ADDRESS:                                |  |                                          |                          |
| CITY:                                           |  | STATE:                                   | ZIP CODE:                |
| TELEPHONE:                                      |  | FAX:                                     |                          |
| CARDHOLDER SIGNATURE:                           |  | CARDHOLDER NAME (PRINT):                 |                          |
|                                                 |  | ORDERED BY:                              |                          |
| EMAIL (REQUIRED FOR RECEIPT):                   |  |                                          |                          |
| WE ACCEPT: VISA / MASTERCARD / AMERICAN EXPRESS |  | CVV:                                     | EXPIRATION DATE:         |
| CC NUMBER HERE:                                 |  |                                          |                          |

**CHARGES WILL APPEAR ON STATEMENT AS "TEAM CO"**

| Qty.                                                                                                                                                                                                                                                                                                                                                                                                                                                 | Description           | Advance Rate          | Regular Rate | Total | TERMS & CONDITIONS                                                                                                                                                                                                                                                                                                                                                                                                                                                                                                                                                                                                                                                                                                                                                                                                                                                                                                                                                                                                                                                                                                                                                                                                                                                                                                                                                                                                                                                                                                                                                                                                                                                                                                                                                                                                                                                                                                                                                                                                                                                                                 |
|------------------------------------------------------------------------------------------------------------------------------------------------------------------------------------------------------------------------------------------------------------------------------------------------------------------------------------------------------------------------------------------------------------------------------------------------------|-----------------------|-----------------------|--------------|-------|----------------------------------------------------------------------------------------------------------------------------------------------------------------------------------------------------------------------------------------------------------------------------------------------------------------------------------------------------------------------------------------------------------------------------------------------------------------------------------------------------------------------------------------------------------------------------------------------------------------------------------------------------------------------------------------------------------------------------------------------------------------------------------------------------------------------------------------------------------------------------------------------------------------------------------------------------------------------------------------------------------------------------------------------------------------------------------------------------------------------------------------------------------------------------------------------------------------------------------------------------------------------------------------------------------------------------------------------------------------------------------------------------------------------------------------------------------------------------------------------------------------------------------------------------------------------------------------------------------------------------------------------------------------------------------------------------------------------------------------------------------------------------------------------------------------------------------------------------------------------------------------------------------------------------------------------------------------------------------------------------------------------------------------------------------------------------------------------------|
| <b>120V LIGHTING &amp; UTILITY OUTLETS</b>                                                                                                                                                                                                                                                                                                                                                                                                           |                       |                       |              |       | Convention Technical Services (CTS) is not responsible for voltage fluctuation or power failure due to temporary conditions including but not limited to losses due to utility company failure, permanent power distribution failure, power failure caused by vandalism, faulty exhibitor equipment or overloads caused by exhibitor. For your protection you should install a surge protector on your computer(s). All electrical installations and connections to all electrical service should be made by a CTS technician. CTS will not be responsible for any damage or loss to any equipment component, computer hardware or software, and/or any damage or injury to any person caused by the installation, connection, or plugging in of any electrical outlet by persons other than a CTS technician.                                                                                                                                                                                                                                                                                                                                                                                                                                                                                                                                                                                                                                                                                                                                                                                                                                                                                                                                                                                                                                                                                                                                                                                                                                                                                     |
|                                                                                                                                                                                                                                                                                                                                                                                                                                                      | 500 Watt or 5 Amps    | 125.00                | 188.00       |       |                                                                                                                                                                                                                                                                                                                                                                                                                                                                                                                                                                                                                                                                                                                                                                                                                                                                                                                                                                                                                                                                                                                                                                                                                                                                                                                                                                                                                                                                                                                                                                                                                                                                                                                                                                                                                                                                                                                                                                                                                                                                                                    |
|                                                                                                                                                                                                                                                                                                                                                                                                                                                      | 1000 Watt or 10 Amps  | 222.00                | 333.00       |       |                                                                                                                                                                                                                                                                                                                                                                                                                                                                                                                                                                                                                                                                                                                                                                                                                                                                                                                                                                                                                                                                                                                                                                                                                                                                                                                                                                                                                                                                                                                                                                                                                                                                                                                                                                                                                                                                                                                                                                                                                                                                                                    |
|                                                                                                                                                                                                                                                                                                                                                                                                                                                      | 2000 Watt or 20 Amps  | 296.50                | 445.00       |       |                                                                                                                                                                                                                                                                                                                                                                                                                                                                                                                                                                                                                                                                                                                                                                                                                                                                                                                                                                                                                                                                                                                                                                                                                                                                                                                                                                                                                                                                                                                                                                                                                                                                                                                                                                                                                                                                                                                                                                                                                                                                                                    |
|                                                                                                                                                                                                                                                                                                                                                                                                                                                      | 30 Amps (Labor Req.)  | <b>CALL FOR QUOTE</b> |              |       |                                                                                                                                                                                                                                                                                                                                                                                                                                                                                                                                                                                                                                                                                                                                                                                                                                                                                                                                                                                                                                                                                                                                                                                                                                                                                                                                                                                                                                                                                                                                                                                                                                                                                                                                                                                                                                                                                                                                                                                                                                                                                                    |
| <b>208V 1 PHASE MOTOR &amp; EQUIPMENT OUTLETS</b>                                                                                                                                                                                                                                                                                                                                                                                                    |                       |                       |              |       |                                                                                                                                                                                                                                                                                                                                                                                                                                                                                                                                                                                                                                                                                                                                                                                                                                                                                                                                                                                                                                                                                                                                                                                                                                                                                                                                                                                                                                                                                                                                                                                                                                                                                                                                                                                                                                                                                                                                                                                                                                                                                                    |
|                                                                                                                                                                                                                                                                                                                                                                                                                                                      | 20 Amp                | 559.00                | 838.50       |       |                                                                                                                                                                                                                                                                                                                                                                                                                                                                                                                                                                                                                                                                                                                                                                                                                                                                                                                                                                                                                                                                                                                                                                                                                                                                                                                                                                                                                                                                                                                                                                                                                                                                                                                                                                                                                                                                                                                                                                                                                                                                                                    |
|                                                                                                                                                                                                                                                                                                                                                                                                                                                      | 30 Amp                | 668.50                | 1003.00      |       |                                                                                                                                                                                                                                                                                                                                                                                                                                                                                                                                                                                                                                                                                                                                                                                                                                                                                                                                                                                                                                                                                                                                                                                                                                                                                                                                                                                                                                                                                                                                                                                                                                                                                                                                                                                                                                                                                                                                                                                                                                                                                                    |
|                                                                                                                                                                                                                                                                                                                                                                                                                                                      | 60 Amp                | 876.00                | 1314.00      |       |                                                                                                                                                                                                                                                                                                                                                                                                                                                                                                                                                                                                                                                                                                                                                                                                                                                                                                                                                                                                                                                                                                                                                                                                                                                                                                                                                                                                                                                                                                                                                                                                                                                                                                                                                                                                                                                                                                                                                                                                                                                                                                    |
|                                                                                                                                                                                                                                                                                                                                                                                                                                                      | 100 Amp               | 1152.00               | 1728.00      |       |                                                                                                                                                                                                                                                                                                                                                                                                                                                                                                                                                                                                                                                                                                                                                                                                                                                                                                                                                                                                                                                                                                                                                                                                                                                                                                                                                                                                                                                                                                                                                                                                                                                                                                                                                                                                                                                                                                                                                                                                                                                                                                    |
| <b>208V 3 PHASE MOTOR &amp; EQUIPMENT OUTLETS</b>                                                                                                                                                                                                                                                                                                                                                                                                    |                       |                       |              |       | <b>Important:</b><br>-To receive advance show prices, we must receive your order, <b>along with payment, in full</b> , within fourteen (14) days prior to show opening. All others will be charged at regular rate.<br>-Any connection required beyond the finished outlet will be charged for time and materials. If you have special needs, please contact us in advance of move-in.<br>-Power sharing <u>is not</u> permitted between exhibitors.<br>-Exhibitors are not permitted to use power unless ordered. Exhibitors found using outlets without an order will be subject to the regular rate for outlets used.<br>-Electricity will be turned on within 30 minutes of show opening and off within 30 minutes after show closing.<br>-Dedicated circuits and 24 hour services will be double the listed price and require a 20 amp outlet. Please double rates. Use * to indicate 24-Hr Outlets.<br>-Refunds will not be authorized if service is installed.<br><b>Outlet Location &amp; Distribution:</b><br>-Island Booths: All electrical outlets for island booths will require labor and materials. Distribution and connections of all outlets are chargeable on a time and materials basis. Please complete a utility diagram with main drop, orientation and dimensions.<br>-Inline & Peninsula Booths: All power is delivered to the back line of the booth at no extra cost. Labor only applies to additional distribution, on a time and materials basis. Please complete a utility diagram for outlets off the back line of the booth.<br>-208V & Higher: Electrical labor required.<br>-Unless a scaled floor plan is provided, electrical will be installed as CTS deems necessary or not at all until direction is given.<br><b>Jurisdiction:</b><br>-All under carpet distribution.<br>-All motor & equipment hook-ups requiring wiring connections.<br>-Labor is required to inspect equipment pre-wired to plug into our system.<br>-Installation and/or repair of electrical fixtures.<br>-Installation of electrical motors and electrical apparatus to be energized. |
|                                                                                                                                                                                                                                                                                                                                                                                                                                                      | 20 Amp                | 745.50                | 1118.00      |       |                                                                                                                                                                                                                                                                                                                                                                                                                                                                                                                                                                                                                                                                                                                                                                                                                                                                                                                                                                                                                                                                                                                                                                                                                                                                                                                                                                                                                                                                                                                                                                                                                                                                                                                                                                                                                                                                                                                                                                                                                                                                                                    |
|                                                                                                                                                                                                                                                                                                                                                                                                                                                      | 30 Amp                | 890.50                | 1336.00      |       |                                                                                                                                                                                                                                                                                                                                                                                                                                                                                                                                                                                                                                                                                                                                                                                                                                                                                                                                                                                                                                                                                                                                                                                                                                                                                                                                                                                                                                                                                                                                                                                                                                                                                                                                                                                                                                                                                                                                                                                                                                                                                                    |
|                                                                                                                                                                                                                                                                                                                                                                                                                                                      | 60 Amp                | 1167.50               | 1751.00      |       |                                                                                                                                                                                                                                                                                                                                                                                                                                                                                                                                                                                                                                                                                                                                                                                                                                                                                                                                                                                                                                                                                                                                                                                                                                                                                                                                                                                                                                                                                                                                                                                                                                                                                                                                                                                                                                                                                                                                                                                                                                                                                                    |
|                                                                                                                                                                                                                                                                                                                                                                                                                                                      | 100 Amp               | 1535.00               | 2302.50      |       |                                                                                                                                                                                                                                                                                                                                                                                                                                                                                                                                                                                                                                                                                                                                                                                                                                                                                                                                                                                                                                                                                                                                                                                                                                                                                                                                                                                                                                                                                                                                                                                                                                                                                                                                                                                                                                                                                                                                                                                                                                                                                                    |
|                                                                                                                                                                                                                                                                                                                                                                                                                                                      | 200 Amp               | 2197.00               | 3295.50      |       |                                                                                                                                                                                                                                                                                                                                                                                                                                                                                                                                                                                                                                                                                                                                                                                                                                                                                                                                                                                                                                                                                                                                                                                                                                                                                                                                                                                                                                                                                                                                                                                                                                                                                                                                                                                                                                                                                                                                                                                                                                                                                                    |
| <b>TRANSFORMER(S) TO BOOST 208V TO 230V</b>                                                                                                                                                                                                                                                                                                                                                                                                          |                       |                       |              |       |                                                                                                                                                                                                                                                                                                                                                                                                                                                                                                                                                                                                                                                                                                                                                                                                                                                                                                                                                                                                                                                                                                                                                                                                                                                                                                                                                                                                                                                                                                                                                                                                                                                                                                                                                                                                                                                                                                                                                                                                                                                                                                    |
| Total Amps:                                                                                                                                                                                                                                                                                                                                                                                                                                          |                       | X \$19.00 / AMP       | =            |       |                                                                                                                                                                                                                                                                                                                                                                                                                                                                                                                                                                                                                                                                                                                                                                                                                                                                                                                                                                                                                                                                                                                                                                                                                                                                                                                                                                                                                                                                                                                                                                                                                                                                                                                                                                                                                                                                                                                                                                                                                                                                                                    |
| <b>480V &amp; ALL OTHER VOLTAGES PLEASE CALL FOR ESTIMATE</b>                                                                                                                                                                                                                                                                                                                                                                                        |                       |                       |              |       |                                                                                                                                                                                                                                                                                                                                                                                                                                                                                                                                                                                                                                                                                                                                                                                                                                                                                                                                                                                                                                                                                                                                                                                                                                                                                                                                                                                                                                                                                                                                                                                                                                                                                                                                                                                                                                                                                                                                                                                                                                                                                                    |
| <b>LIFT</b>                                                                                                                                                                                                                                                                                                                                                                                                                                          |                       |                       |              |       |                                                                                                                                                                                                                                                                                                                                                                                                                                                                                                                                                                                                                                                                                                                                                                                                                                                                                                                                                                                                                                                                                                                                                                                                                                                                                                                                                                                                                                                                                                                                                                                                                                                                                                                                                                                                                                                                                                                                                                                                                                                                                                    |
| 1 HOUR MINIMUM INSTALL & ½ HOUR MINIMUM DISMANTLE                                                                                                                                                                                                                                                                                                                                                                                                    |                       |                       |              |       |                                                                                                                                                                                                                                                                                                                                                                                                                                                                                                                                                                                                                                                                                                                                                                                                                                                                                                                                                                                                                                                                                                                                                                                                                                                                                                                                                                                                                                                                                                                                                                                                                                                                                                                                                                                                                                                                                                                                                                                                                                                                                                    |
| LIFT                                                                                                                                                                                                                                                                                                                                                                                                                                                 |                       | ST                    | 275.00       |       |                                                                                                                                                                                                                                                                                                                                                                                                                                                                                                                                                                                                                                                                                                                                                                                                                                                                                                                                                                                                                                                                                                                                                                                                                                                                                                                                                                                                                                                                                                                                                                                                                                                                                                                                                                                                                                                                                                                                                                                                                                                                                                    |
| LIFT                                                                                                                                                                                                                                                                                                                                                                                                                                                 |                       | OT                    | 412.50       |       |                                                                                                                                                                                                                                                                                                                                                                                                                                                                                                                                                                                                                                                                                                                                                                                                                                                                                                                                                                                                                                                                                                                                                                                                                                                                                                                                                                                                                                                                                                                                                                                                                                                                                                                                                                                                                                                                                                                                                                                                                                                                                                    |
| <b>FLOODLIGHTS &amp; TRACK</b>                                                                                                                                                                                                                                                                                                                                                                                                                       |                       |                       |              |       |                                                                                                                                                                                                                                                                                                                                                                                                                                                                                                                                                                                                                                                                                                                                                                                                                                                                                                                                                                                                                                                                                                                                                                                                                                                                                                                                                                                                                                                                                                                                                                                                                                                                                                                                                                                                                                                                                                                                                                                                                                                                                                    |
| <b>LABOR: ST \$140.00 – OT \$210.00</b>                                                                                                                                                                                                                                                                                                                                                                                                              |                       |                       |              |       |                                                                                                                                                                                                                                                                                                                                                                                                                                                                                                                                                                                                                                                                                                                                                                                                                                                                                                                                                                                                                                                                                                                                                                                                                                                                                                                                                                                                                                                                                                                                                                                                                                                                                                                                                                                                                                                                                                                                                                                                                                                                                                    |
| Office Use Only                                                                                                                                                                                                                                                                                                                                                                                                                                      |                       |                       |              |       |                                                                                                                                                                                                                                                                                                                                                                                                                                                                                                                                                                                                                                                                                                                                                                                                                                                                                                                                                                                                                                                                                                                                                                                                                                                                                                                                                                                                                                                                                                                                                                                                                                                                                                                                                                                                                                                                                                                                                                                                                                                                                                    |
|                                                                                                                                                                                                                                                                                                                                                                                                                                                      | 150 Watt Flood Light  | 125.00                | 188.00       |       |                                                                                                                                                                                                                                                                                                                                                                                                                                                                                                                                                                                                                                                                                                                                                                                                                                                                                                                                                                                                                                                                                                                                                                                                                                                                                                                                                                                                                                                                                                                                                                                                                                                                                                                                                                                                                                                                                                                                                                                                                                                                                                    |
|                                                                                                                                                                                                                                                                                                                                                                                                                                                      | Double 150 Watt Flood | 208.50                | 313.00       |       |                                                                                                                                                                                                                                                                                                                                                                                                                                                                                                                                                                                                                                                                                                                                                                                                                                                                                                                                                                                                                                                                                                                                                                                                                                                                                                                                                                                                                                                                                                                                                                                                                                                                                                                                                                                                                                                                                                                                                                                                                                                                                                    |
|                                                                                                                                                                                                                                                                                                                                                                                                                                                      | *Overhead/Can/Leko    | 348.00                | 522.00       |       |                                                                                                                                                                                                                                                                                                                                                                                                                                                                                                                                                                                                                                                                                                                                                                                                                                                                                                                                                                                                                                                                                                                                                                                                                                                                                                                                                                                                                                                                                                                                                                                                                                                                                                                                                                                                                                                                                                                                                                                                                                                                                                    |
| <b>*Overhead light may require labor and lift to install. First focus included. Call for a quote. Lighting Layout Required for Overhead Lights*</b><br>CTS does not determine the move-in and move-out schedule for any event. Hourly rates apply to actual dates and times of install & dismantle.<br>ST – Labor after 8:00am and before 4:30pm, weekdays.<br>OT – Labor before 8:00am and after 4:30pm, weekdays. Weekends & Holidays are also OT. |                       |                       |              |       |                                                                                                                                                                                                                                                                                                                                                                                                                                                                                                                                                                                                                                                                                                                                                                                                                                                                                                                                                                                                                                                                                                                                                                                                                                                                                                                                                                                                                                                                                                                                                                                                                                                                                                                                                                                                                                                                                                                                                                                                                                                                                                    |





6455 S. Dean Martin Dr., Suite C \* Las Vegas, Nevada 89118  
Telephone: (702) 309-8326

## Sample Layouts

**Island Booth: Electrical layouts are required for all island booths.**

### Standard Location:

There is no such thing as a standard location in an island booth. There will be labor and material required to install the outlet ordered. If a layout is not provided, we will place power at our discretion.

### What should be on a completed floor plan:

1. Main drop or outlet location. Island booths do not have a back wall so the main location operates as the point which all other power will be distributed from. There can often be many cords or cables in this location so it is often best to be in a closet, under a table or a location out of site.
2. Location of all other outlets. This includes the dimensions where the outlets will be placed. Without dimensions, outlets are likely to end up in the wrong locations in the booth.
3. Power requirements in each location. This can be 500 Watts / 1000 Watts / 2000 Watts or even 10 Amp 208 volt 3 Phase
4. Booth Orientation. This is especially useful for island booths. It helps us understand which side is which in the booth.

### Completed Layout:

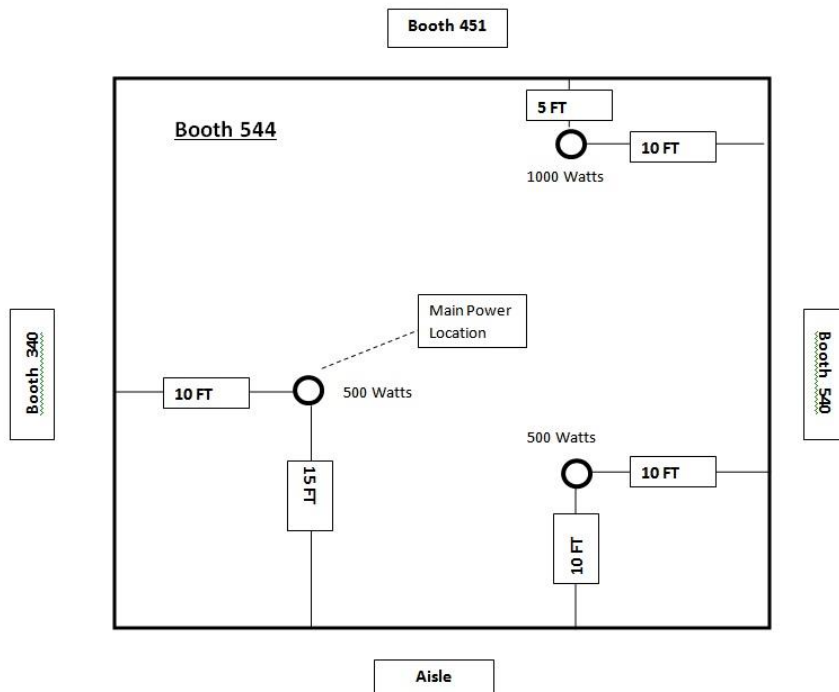

**Inline or Peninsula Booths:**

Layouts are only required when outlets are needed at any other location than the back of the booth.

Standard Location:

In Line

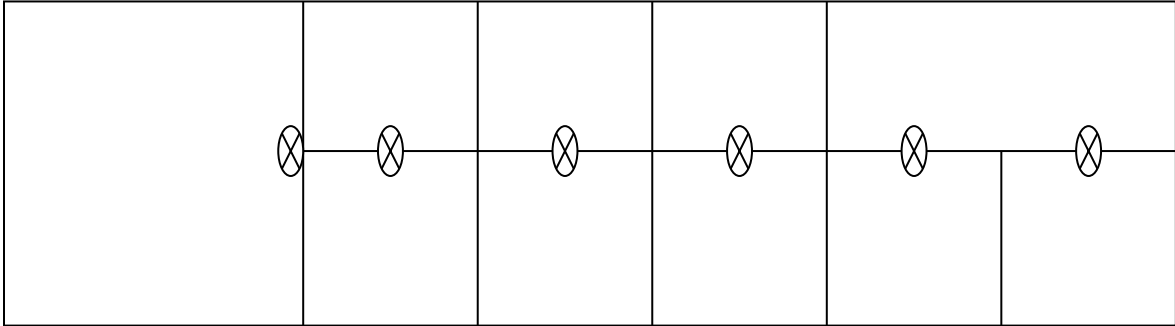

Completed Layout:

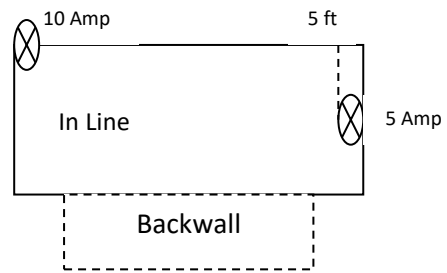
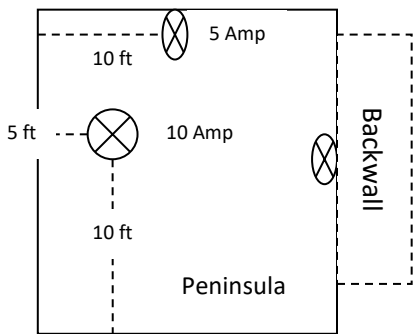

Thank you for your business!